

**Gross Power**  
142 kW(190 hp) at 2,200rpm

**Net Power**  
138 kW(185 hp) at 2,200rpm

**Bucket Capacity**  
1.08 ~ 1.50m<sup>3</sup>

**Operating Weight**  
26,060 kg / 57,450 lb

# HX260 L

With Tier 3 / Stage IIIA Engine Installed



## ▲ HYUNDAI CONSTRUCTION EQUIPMENT

Head Office(Sales Office)

3F, Bundang First Tower, 55 Bundang-ro, Bundang-gu, Seongnam-si, Gyeonggi-do, 13591, Korea

PLEASE CONTACT



# RULE THE GROUND

**HX260 L**

HX-LT3 Series exceeds customer's expectation!

Become a true leader on the ground with HCE's HX-LT3 series.

## WORK MAX, WORTH MAX

- IPC (Intelligent Power Control) **Upgrade**
- Attachment Flow Control **Option**
- New Variable Power Control
- Fuel Rate Information
- ECO Gauge
- New Cooling System with Increased Air Flow
- Enlarged Air Inlet with Grill Cover

## MORE RELIABLE, MORE SUSTAINABLE

- Durable Cooling Module
- Reinforced Pin, Bush, and Polymer Shim
- Reinforced Durability of Upper and Lower Structure and Attachments
- Wear Resistant Cover Plate
- Hi-grade (High-pressure) Hoses

## INFOTAINMENT FRONTIER

- Proportional Auxiliary Hydraulic System **Option**
- Quick Coupler Button **Option**
- New Front Side Air-conditioning System
- Intelligent and Wide Cluster
- New Air Conditioning System
- Audio System



## MODERN COMFORT, SIMPLE AND SAFE SOLUTION

- AAVM (Advanced Around View Monitoring) Camera System **Option**
- Hi MATE (Remote Management System) **Option**
- Swing Lock System **Option**
- Fine Swing Control **Option**
- Cab Suspension Mount

BETTER FUEL-EFFICIENCY (Compared to 9 Series)

Truck Loading  
**5.6%**

Leveling  
**13.8%**

Daily Fuel Efficiency  
**8.5%**



# WORK MAX, WORTH MAX

## Fuel Efficient System Allows Great Performance

HX-LT3 Series has an eco-friendly, high-performance engine which ensures both excellent fuel efficiency and high power. With outstanding operating performance proven by rigorous tests at various work sites, it will satisfy any customer's needs.

\* Photo may include optional equipment.

## IPC (Intelligent Power Control)

Upgrade

HX-LT3 Series adopts the upgraded IPC system. It is able to optimize pump flow rate and power at the various working condition through the individual pump control. Furthermore, optimized design of MCV and pipe line minimizes energy loss such as conflux and throttle loss.



## Attachment Flow Control Option

HX-LT3 Series improves pump flow rate by independent control of two pumps. It optimizes attachments for effective flow rate setting depending on attachments (ten breaker types and ten crusher types), enabling various operations matching the site environments.



## Fuel Rate Information



15% increased greater screen from 7 to 8 inch is applied in HX-LT3 Series. More functions and better resolution are available with adding premium options.

## New Variable Power Control

HX LT3 Series minimizes equipment input and output control signals to improve fuel efficiency. Its three-stage power mode ensures the highest performance in any operating environment.

\*P(power) mode : Maximizes speed and power of the equipment for heavy load work.

\*S(standard) mode : Optimizes performance and fuel efficiency of the equipment for general load work.

\*E(economy) mode : Improves the control system for light load work.

## New Cooling System with Increased Air Flow

With the three-floor vertically placed cooling module improving air inflow, HX-LT3 Series provides excellent cooling performance by increasing heat dissipation and can be easily cleaned.



## Enlarged Air Inlet with Grill Cover

Enlarged vent hole of the air inlet side cover and fine net grill to prevent penetration of foreign materials further improve durability.



## Eco Gauge

Eco gauge enables economic operation of machines. The gauge level and color displays engine torque and fuel efficiency level. On top of that, the status of fuel consumption such as average rate and the total amount of fuel consumed is displayed. Hourly and daily based fuel consumption can be checked in the detailed menu as well.





**We make the best performance in rough working conditions without any unsureness with trustworthy HX260 L.**



#### **Durable Cooling Module**

HX-LT3 Series has a durable cooling module that passed stringent tests, demonstrating the highest productivity in tough working environments.

#### **Reinforced Durability of Upper and Lower Structure and Attachments**

The upper and lower structure and attachments of HX-LT3 Series have higher durability than demanded on the site, as proven through numerous tests including road tests and virtual simulation. The wear resistance of the bucket has been improved by use of new material.



#### **Reinforced Pins, Bushing, and Polymer Shims**

HX-LT3 Series improves lubricity of connecting parts between the equipment and attachments. Gaps with attachments are minimized by wear-resistant long-life pins, bushes, and polymer shims, supporting the highest performance with invariable durability.

Chrome Coated Pins



#### **Wear Resistant Cover Plate**

A wear-resistant cover plate is installed at the end of the arm to minimize abrasion on the connector between the arm and the bucket. Vibration reduction of buckets enables more stable operation even in high-load work.

#### **Hi-grade (High-pressure) Hoses**

HX-LT3 Series uses high-pressure hoses with improved heat and pressure resistance, greatly increasing the durability of the equipment.



# **MORE RELIABLE, MORE SUSTAINABLE**

#### **New Exterior Design for Robustness and Safety**

The true value of HX-LT3 Series lies in its durability. The robust frame structure and the attachments show the real value of HX-LT3 Series in tough working environments and promise higher productivity.

Image may include optional equipment.

13%

CABIN SPACE FOR DRIVERS INCREASED BY  
(Compared to the previous model)

310mm  
340mm



# INFOTAINMENT FRONTIER

## Improved Instrument Panel for Easier Monitoring

Many electronic functions are concentrated in the most convenient spot for operators to improve work efficiency. The highly-advanced infotainment system, a product of HCE's intensive information technology development, enables both productivity and comfort while working! HX-LT3 Series is designed with the operator in mind.

\* Photo may include optional equipment.

## New Front Side Air-conditioning System

The ventilation is designed for both warm and cool air reaching to operator's faces. It could helps operators create more neat and enjoyable atmosphere through indoor air circulation.



## Audio System

The radio player with a USB-based MP3 player, an integrated Bluetooth hands-free feature, and a built-in microphone allow for phone calls while at work and in transit. The radio player is conveniently located on the right side of the operator to allow for improved access.



## Quick Coupler Button Option

Easy attachment replacement of equipment is available with quick coupler button.



## Proportional Auxiliary Hydraulic System Option

Proportional control switch with better speed control helps operators to enlarge the operation convenience whenever they do time-consuming work.



## Intelligent and Wide Cluster

The 8" capacitive-type display(like smartphone display) of HX-LT3 Series is delivering excellent legibility. The centralized display allow convenience of checking RPM, fuel gauge, temperature of hydraulic oil and coolant.



## New Air Conditioning System

Front side Air Vent holes make operators more convenient and fresh through direct air flow to driver's face, foot and body.



## HX260 L with advanced technology ensures our safety on a construction site.



HX-LT3 Series excavators are products of HCE's spirit of initiative, creativity, and strong drive. HCE engineers, who are the best in the industry, have worked tirelessly to offer a zero-defect product. The new HX-LT3 Series reflects customers' needs in the field gleaned by thorough monitoring.

### AAVM(Advanced Around View Monitoring) Camera System

Option

HX-LT3 Series has a state-of-the-art AAVM video camera system to secure field of vision for operators in all directions, thereby preventing accidents. Operators can easily check the workplace in the front and rear and to the right and left.

- **AAVM**(Advanced Around View Monitoring) : Secure field of vision in all directions by ten views including 3D bird's eye view and 2D/4CH view.
- **IMOD**(Intelligent Moving Object Detection) : Inform when people or dangerous objects are detected within the range of operation(recognition distance : 5 m).

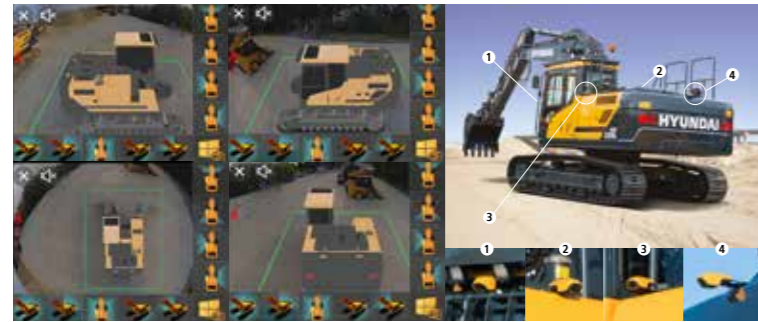

### Swing Lock System

Option

Swing lock system is provided to maintain stability when swing movement needs to be limited, improving operating speed and productivity.

### Fine Swing Control

Option

This option enables smooth movement at the start and stop of swing operation(Cushion Swing).

### Cabin Suspension Mount

With a low-vibration design by the coil spring and damper inside the mount, the cab suspension mount of HX-LT3 Series reduces noise inside the cabin and improves durability, providing a comfortable operation space that lessens operators' fatigue.

# HiMATE

Option

## IT'S CONVENIENT, EASY AND VALUABLE

Hi MATE Hyundai's newly developed remote management system, utilizes GPS-satellite technology to provide customers with the highest level of service and product support available. Hi MATE enables users to remotely evaluate machine performance, access diagnostic information, and verify machine locations at the touch of a button.

### WHAT IS BENEFITS



#### Increase Productivity

It helps you operate machines in efficient. You can check the difference between total engine hours and actual working hours. See how productive your machines are and plan any required cost saving solutions. Hi MATE offers working information such as working / idling hours, fuel consumption and rate.



#### Convenient and Easy Monitoring

There is nothing much to do to monitor your machines. Just log on to the Hi MATE website or mobile application. Hi MATE allows you to watch your machines whenever and wherever you are.



#### Security

Protect your machines from theft or unauthorized usage with Hi MATE. If the machine moves out of the Geofence boundary, you will get alerts.



# MODERN COMFORT, SIMPLE AND SAFE SOLUTION

### New Cabin for More Comfort

Low noise, low vibration, and ergonomic design make the cabin space more comfortable and pleasant! With focus on safety and convenience of operators, HX-LT3 Series allows rapid and safe equipment inspection anytime and anywhere, providing an optimal environment for operators to work.



\*Photo may include optional equipment.

# SPECIFICATIONS

ENGINE	
Maker / Model	HYUNDAI / HE6.7
Type	6 cylinder, water cooled, 4-cycle, turbocharged, charge air cooled, direct injection, electronic controlled diesel engine
Gross Power	142 kW (190 hp) at 2,200 rpm
Net Power	138 kW (185 hp) at 2,200 rpm
Max. Power	145 kW (195 hp) at 2,000 rpm
Peak Torque	929 N · m (685 lb · ft) at 1,400 rpm
Displacement	6.7ℓ (408 cu in)

HYDRAULIC SYSTEM	
MAIN PUMP	
Type	Variable displacement tandem axis piston pumps
Max. flow	2×247 lpm (65.2U.S. gpm / 54.3U.K. gpm)
Sub-pump for pilot circuit	Gear pump
Cross-sensing and fuel saving pump system	

HYDRAULIC MOTORS	
Travel	Two-speed axial pistons motor with brake valve and parking brake
Swing	Axial piston motor with automatic brake

RELIEF VALVE SETTING	
Implement circuits	350 kgf/cm <sup>2</sup> (4,978 psi)
Travel	350 kgf/cm <sup>2</sup> (4,978 psi)
Power boost (boom, arm, bucket)	380 kgf/cm <sup>2</sup> (5,404 psi)
Swing circuit	300 kgf/cm <sup>2</sup> (4,267 psi)
Pilot circuit	40 kgf/cm <sup>2</sup> (568 psi)
Service valve	Installed

HYDRAULIC CYLINDERS	
No. of cylinder bore X stroke	Boom 2-135 X 1,395 mm Arm 1-145 X 1,620 mm Bucket 1-130 X 1,185 mm

DRIVES & BRAKES	
Drive method	Fully hydrostatic type
Drive motor	Axial piston motor, in-shoe design
Reduction system	Planetary reduction gear
Max. drawbar pull	22,193 kgf (48,927 lbf)
Max. travel speed (high / low)	5.6 km/hr (3.5 mph) / 3.2 km/hr (2.0 mph)
Gradeability	35° (70%)
Parking brake	Multi wet disc

CONTROL	
Pilot pressure operated joysticks and pedals with detachable lever provide almost effortless and fatigueless operation.	
Pilot control (ISO Type)	Two joysticks with one safety lever (LH): Swing and arm, Boom and bucket
Traveling and steering	Two levers with pedals
Engine throttle	Electric, Dial type
Lights	Two lights mounted on the boom, Two lights mounted on the frame

SWING SYSTEM	
Swing motor	Fixed displacement axial piston motor
Swing reduction	Planetary gear reduction
Swing bearing lubrication	Grease-bathed
Swing brake	Multi wet disc
Swing speed	10.9 rpm

COOLANT & LUBRICANT CAPACITY			
	liter	US gal	UK gal
Fuel tank	450.0	118.9	99.0
Engine coolant	35.0	9.2	7.7
Engine oil	23.7	6.3	5.2
Swing device	6.0	1.6	1.3
Final drive (each)	3.3	0.87	0.73
Hydraulic system (including tank)	275.0	72.6	60.5
Hydraulic tank	160.0	42.3	35.2

UNDERCARRIAGE		
The X-leg type center frame is integrally welded with reinforced box-section track frames. The undercarriage includes lubricated rollers, idlers, track adjusters with shock absorbing springs and sprockets, and a track chain with double or triple grouser shoes.		
Center frame	X - leg type	
Track frame	Pentagonal box type	
Model	HX260L	HX260L HW
No. of shoes on each side	51	48
No. of carrier roller on each side	2	2
No. of track roller on each side	9	9
No. of rail guard on each side	2	-

OPERATING WEIGHT (APPROXIMATE)			
Operating weight, including 5.85m (19' 2") boom, 3.05m (10' 0") arm, SAE heaped 1.08m <sup>3</sup> (1.40 yd <sup>3</sup> ) bucket, lubricant, coolant, full fuel tank, full hydraulic tank, and all standard equipments.			

OPERATING WEIGHT				
Type	Shoes	Operating Weight		Ground Pressure
		Width mm (in)	kg (lb)	
Triple Grouser	600 (24")	HX260L	26,060 (57,452)	0.53 (7.54)
		HX260L HW	30,710 (67,703)	0.59 (8.41)
	700 (28")	HX260L	26,370 (58,135)	0.46 (6.54)
		HX260L HW	31,300 (69,004)	0.52 (7.35)
Double Grouser	800 (32")	HX260L	26,670 (58,797)	0.41 (5.79)
	900 (36")	HX260L	26,980 (59,480)	0.37 (5.20)
	700 (28")	HX260L HW	32,340 (71,297)	0.53 (7.58)

AIR CONDITIONING SYSTEM	
The air condition system for the machine contains the fluorinated greenhouse gas with global warming potential of R134a. (Global Warming Potential : 1,430) The system hold 0.8kg refrigerant consisting of a CO <sub>2</sub> equivalent 1.1kg metric tonne. For more information, Please refer to the manual.	

# BUCKET SELECTION GUIDE & DIGGING FORCE

BUCKETS				
				
SAE heaped	1.08 (1.41)	1.27 (1.66)	1.50 (1.96)	
m <sup>3</sup> (yd <sup>3</sup> )				

Capacity m <sup>3</sup> (yd <sup>3</sup> )	Width mm (in)	Weight kg (lb)	Tooth EA	Recommendation mm(ft-in)				
				5,850 (19' 2") Boom				
SAE heaped	CECE heaped			2,100 (6' 11") Arm	2,500 (8' 2") Arm	3,050 (10' 0") Arm	3,600 (11' 10") Arm	
1.08 (1.41)	0.95 (1.24)	1,130 (44.5")	910 (2,010)	5	●	●	●	●
1.27 (1.66)	1.10 (1.44)	1,290 (50.8")	1,010 (2,230)	5	●	●	○	■
1.50 (1.96)	1.30 (1.70)	1,490 (58.7")	1,080 (2,380)	5	○	○	■	x

- : Applicable for materials with density of 2,100 kg/m<sup>3</sup> (3,500 lb/yd<sup>3</sup>) or less
- : Applicable for materials with density of 1,800 kg/m<sup>3</sup> (3,000 lb/yd<sup>3</sup>) or less
- : Applicable for materials with density of 1,500 kg/m<sup>3</sup> (2,500 lb/yd<sup>3</sup>) or less
- ▲ : Applicable for materials with density of 1,200 kg/m<sup>3</sup> (2,000 lb/yd<sup>3</sup>) or less
- x : Not Recommended

ATTACHMENT	
Booms and arms are of all-welded, low-stress, full-box section design. 5,850 mm (19' 2") boom and 2,100 mm (6' 11"), 2,500 mm (8' 2"), 3,050 mm (10' 0"), 3,600 mm (11' 10") arms are available, Hyundai Bucket are all-welded, high-strength steel implements.	

DIGGING FORCE							
Boom	Length	mm (ft-in)	5,850 (19' 2")				Remarks
	Weight	kg (lb)	2,460 (5,420)				
Arm	Length	mm (ft-in)	2,100 (6' 11")	2,500 (8' 2")	3,050 (10' 0")	3,600 (11' 10")	[ ] : Power Boost
	Weight	kg (lb)	1,420 (3,130)	1,450 (3,200)	1,540 (3,400)	1,600 (3,530)	
Bucket digging force	SAE	kN	153.1 [166.1]	153.6 [167.2]	154.0 [167.2]	154.1 [167.2]	
		kgf	15,600 [16,940]	15,700 [17,050]	15,700 [17,050]	15,700 [17,050]	
	ISO	lbf	34,403 [37,350]	34,522 [37,590]	34,603 [37,590]	34,638 [37,590]	
		kN	177.2 [192.7]	177.8 [192.7]	178.2 [193.8]	178.4 [193.8]	
Arm crowd force	SAE	kgf	18,100 [19,650]	18,100 [19,650]	18,200 [19,760]	18,200 [19,760]	
		lbf	39,819 [43,320]	39,957 [43,320]	40,051 [43,560]	40,092 [43,560]	
	ISO	kN	159.2 [172.5]	134.3 [145.8]	113.3 [122.5]	103.1 [111.8]	
		kgf	16,200 [17,590]	13,700 [14,870]	11,500 [12,490]	10,500 [11,400]	
	ISO	lbf	35,777 [38,780]	30,188 [32,780]	25,461 [27,540]	23,170 [25,130]	
		kN	167.7 [182.1]	140.8 [153.3]	118.2 [127.8]	107.0 [116.0]	
		kgf	17,100 [18,570]	14,400 [15,630]	12,000 [13,030]	10,900 [11,830]	
		lbf	37,698 [40,940]	31,651 [34,460]	26,553 [28,730]	24,056 [26,080]	

Note : Boom weight includes arm cylinder, piping, and pin  
Arm weight includes bucket cylinder, linkage, and pin

# DIMENSIONS & WORKING RANGE

## HX260 L DIMENSIONS

5.85 m (19' 2") BOOM and 2.1 m (6' 11"), 2.5 m (8' 2"), 3.05 m (10' 0"), 3.6 m (11' 10") ARM

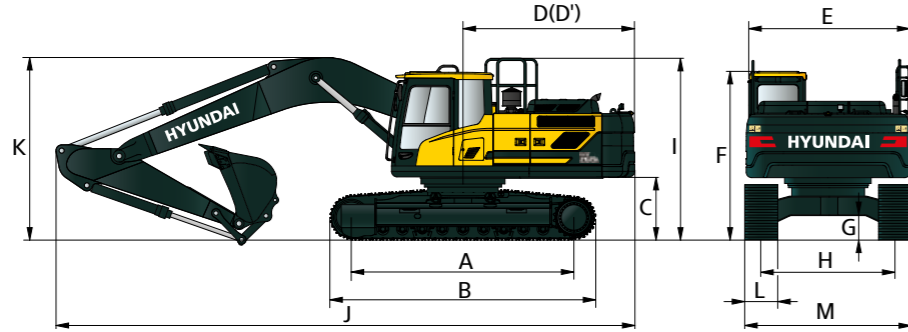

Unit : mm (ft.-in)

A Tumbler distance	3,830 (12' 7")
B Overall length of crawler	4,640 (15' 3")
* C Ground clearance of counterweight	1,110 (3' 8")
D Tail swing radius	3,085 (10' 1")
D' Rear-end length	2,990 (9' 10")
E Overall width of upperstructure	2,840 (9' 4")
* F Overall height of cab	3,050 (10' 0")
* G Min. ground clearance	480 (1' 7")
H Track gauge	2,580 (8' 6")
* I Overall height of guardrail	3,260 (10' 8")

Boom length	5,850 (19' 2")			
Arm length	2,100 (6' 11")	2,500 (8' 2")	3,050 (10' 0")	3,600 (11' 10")
J Overall length	10,170 (33' 4")	10,070 (33' 0")	10,010 (32' 10")	10,040 (32' 11")
* K Overall height of boom	3,480 (11' 5")	3,360 (11' 0")	3,230 (10' 7")	3,360 (11' 0")
L Track shoe Width	Type	Triple grouser		
	Width	600 (1' 12")	700 (2' 4")	800 (2' 7")
M Overall Width	3,180 (10' 5")	3,280 (10' 9")	3,380 (11' 1")	3,280 (10' 9")

\* This figure includes the size of grousers.

# DIMENSIONS & WORKING RANGE

## HX260 L HIGH WALKER DIMENSIONS

5.85 m (19' 2") BOOM and 2.1 m (6' 11"), 2.5 m (8' 2"), 3.05 m (10' 0"), 3.6 m (11' 10") ARM

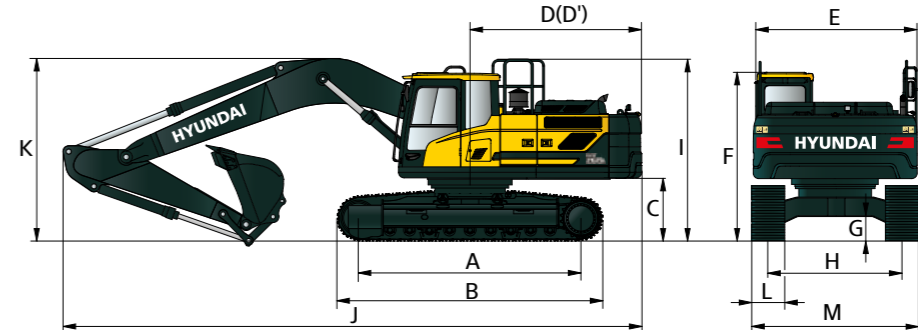

Unit : mm (ft.-in)

A Tumbler Distance	4,030 (13' 3")
B Overall Length of Crawler	4,940 (16' 2")
* C Ground Clearance of Counter weight	1,475 (4' 10")
D Tail Swing Radius	3,085 (10' 1")
D' Rear-End Length	2,990 (9' 10")
*** E Overall Width of Upperstructure	2,840 (9' 4")
* F Overall Height of Cab	3,395 (11' 2")
* G Min. Ground Clearance	765 (2' 6")
H Track Gauge	2,790 (9' 2")
* I Overall height of guardrail	3,625 (11' 11")

Boom Length	5,850 (19' 2")			
Arm Length	2,100 (6' 11")	2,500 (8' 2")	3,050 (10' 0")	3,600 (11' 10")
J Overall Length	10,160 (33' 4")	10,020 (32' 10")	9,870 (32' 5")	10,040 (32' 11")
* K Overall Height of Boom	3,630 (11' 11")	3,460 (11' 4")	3,220 (10' 7")	3,610 (11' 10")
L Track Shoe Width	Type	Triple grouser		Double grouser
	Width	600 (24")	700 (28")	700 (28")
** M Overall Width	3,470 (11' 5")	3,490 (11' 5")	3,490 (11' 5")	

\* This figure includes the size of grousers.  
\*\* without extended foot board.  
\*\*\* without catwalk.

## HX260 L WORKING RANGE

Unit : mm (ft.-in)

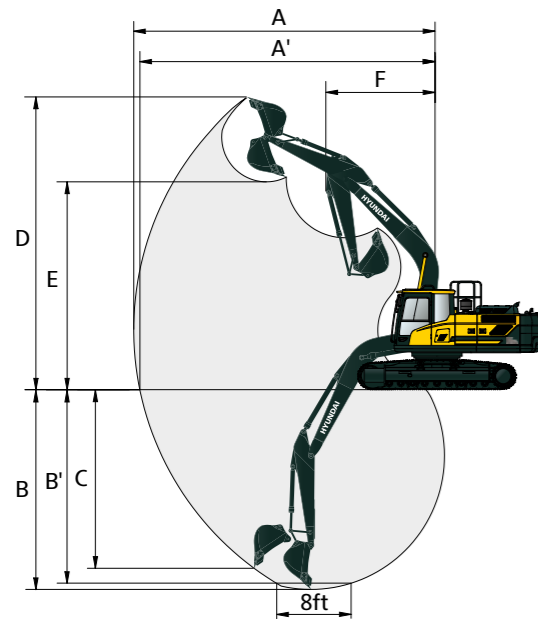

Boom length	5,850 (19' 2")			
Arm length	2,100 (6' 11")	2,500 (8' 2")	3,050 (10' 0")	3,600 (11' 10")
A Max. digging reach	9,560 (31' 4")	9,870 (32' 5")	10,360 (34' 0")	10,870 (35' 8")
A' Max. digging reach on ground	9,370 (30' 9")	9,690 (31' 9")	10,190 (33' 5")	10,710 (35' 2")
B Max. digging depth	6,060 (19' 11")	6,460 (21' 2")	7,010 (23' 0")	7,560 (24' 10")
B' Max. digging depth (8' level)	5,850 (19' 2")	6,280 (20' 7")	6,850 (22' 6")	7,420 (24' 4")
C Max. vertical digging depth	5,520 (18' 1")	5,680 (18' 8")	6,170 (20' 3")	6,860 (22' 6")
D Max. digging height	9,950 (32' 8")	10,020 (32' 10")	10,260 (33' 8")	10,560 (34' 8")
E Max. dumping height	6,800 (22' 4")	6,900 (22' 8")	7,150 (23' 5")	7,430 (24' 5")
F Min. swing radius	3,840 (12' 7")	3,190 (10' 6")	3,450 (11' 4")	3,150 (10' 4")

## HX260 L HIGH WALKER WORKING RANGE

Unit : mm (ft.-in)

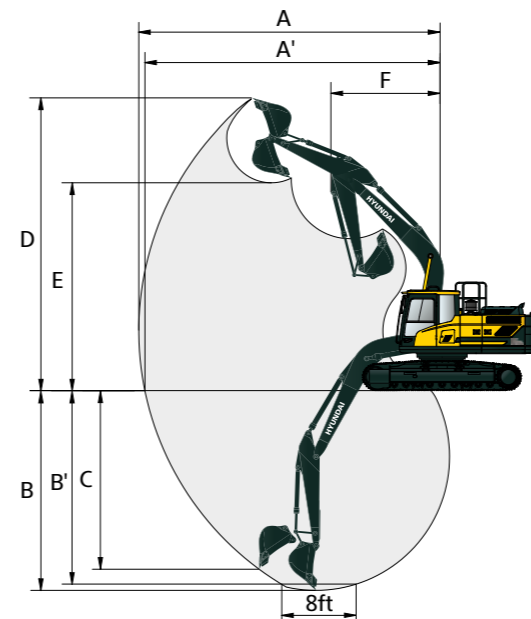

Boom length	5,850 (19' 2")			
Arm length	2,100 (6' 11")	2,500 (8' 2")	3,050 (10' 0")	3,600 (11' 10")
A Max. digging reach	9,560 (31' 4")	9,870 (32' 5")	10,360 (34' 0")	10,870 (35' 8")
A' Max. digging reach on ground	9,290 (30' 6")	9,610 (31' 6")	10,120 (33' 2")	10,640 (34' 11")
B Max. digging depth	5,700 (18' 8")	6,100 (20' 0")	6,650 (21' 10")	7,200 (23' 7")
B' Max. digging depth (8' level)	5,490 (18' 0")	5,910 (19' 5")	6,490 (21' 4")	7,050 (23' 2")
C Max. vertical digging depth	5,150 (16' 11")	5,320 (17' 5")	5,810 (19' 1")	6,500 (21' 4")
D Max. digging height	10,310 (33' 10")	10,380 (34' 1")	10,620 (34' 10")	10,920 (35' 10")
E Max. dumping height	7,160 (23' 6")	7,260 (23' 10")	7,510 (24' 8")	7,790 (25' 7")
F Min. swing radius	3,840 (12' 7")	3,190 (10' 6")	3,450 (11' 4")	3,150 (10' 4")



# LIFTING CAPACITY

Rating over-front Rating over-side or 360 degree

## HX260 L

5.85 m (19' 2") boom, 2.10 m (6' 9") arm equipped triple grouser shoe. (without bucket)

Lift-point height (m/ft)	Lift-point radius								At max. reach		
	3.0 m (9.8 ft)		4.5 m (14.8 ft)		6.0 m (19.7 ft)		7.5 m (24.6 ft)		Capacity		Reach
											m (ft)
7.5 m 24.6 ft	kg lb								*7,270 *16,030	*7,270 *16,030	5.55 (18.2)
6.0 m 19.7 ft	kg lb		*7,450 *16,420	*7,450 *16,420	*7,020 *15,480	6,840 15,080			*7,120 *15,700	5,570 12,280	6.77 (22.2)
4.5 m 14.8 ft	kg lb		*9,300 *20,500	*9,300 *20,500	*7,680 *16,930	6,610 14,570			6,980 15,390	4,650 10,250	7.49 (24.6)
3.0 m 9.8 ft	kg lb				*8,750 *19,290	6,300 13,890	6,850 15,100	4,540 10,010	6,360 14,020	4,220 9,300	7.86 (25.8)
1.5 m 4.9 ft	kg lb				9,390 20,700	6,030 13,290	6,720 14,820	4,410 9,720	6,190 13,650	4,080 8,990	7.93 (26.0)
Ground Line	kg lb		*14,160 *31,220	8,870 19,550	9,220 20,330	5,880 12,960	6,640 14,640	4,350 9,590	6,400 14,110	4,200 9,260	7.70 (25.3)
-1.5 m -4.9 ft	kg lb		*13,770 *30,360	8,910 19,640	9,210 20,300	5,870 12,940			7,130 15,720	4,660 10,270	7.16 (23.5)
-3.0 m -9.8 ft	kg lb	*16,820 *37,080	*16,820 *37,080	*12,420 *27,380	9,090 20,040	*9,100 *20,060	6,030 13,290		*8,600 *18,960	5,780 12,740	6.20 (20.4)
-4.5 m -14.8 ft	kg lb										

5.85 m (19' 2") boom, 2.50 m (8' 2") arm equipped triple grouser shoe. (without bucket)

Lift-point height (m/ft)	Lift-point radius								At max. reach			
	3.0 m (9.8 ft)		4.5 m (14.8 ft)		6.0 m (19.7 ft)		7.5 m (24.6 ft)		Capacity		Reach	
											m (ft)	
7.5 m 24.6 ft	kg lb								*6,090 *13,430	*6,090 *13,430	6.00 (19.7)	
6.0 m 19.7 ft	kg lb			*6,490 *14,310	*6,490 *14,310				*5,660 *12,480	5,160 11,380	7.14 (23.4)	
4.5 m 14.8 ft	kg lb		*8,580 *18,920	*8,580 *18,920	*7,240 *15,960	6,680 14,730	*6,730 *14,840	4,690 10,340	*5,590 *12,320	4,360 9,610	7.82 (25.7)	
3.0 m 9.8 ft	kg lb		*11,110 *24,490	9,690 21,360	*8,360 *18,430	6,350 14,000	6,870 15,150	4,550 10,030	*5,750 *12,680	3,970 8,750	8.18 (26.8)	
1.5 m 4.9 ft	kg lb		*13,180 *29,060	9,100 20,060	9,430 20,790	6,060 13,360	6,720 14,820	4,410 9,720	5,830 12,850	3,840 8,470	8.25 (27.1)	
Ground Line	kg lb		*14,060 *31,000	8,860 19,530	9,220 20,330	5,870 12,940	6,610 14,570	4,320 9,520	6,000 13,230	3,930 8,660	8.03 (26.3)	
-1.5 m -4.9 ft	kg lb	*11,530 *25,420	*11,530 *25,420	*13,950 *30,750	8,840 19,490	9,160 20,190	5,820 12,830	6,620 14,590	4,320 9,520	6,610 14,570	4,310 9,500	7.51 (24.6)
-3.0 m -9.8 ft	kg lb	*18,010 *39,710	*18,010 *39,710	*12,910 *28,460	8,980 19,800	9,270 20,440	5,920 13,050		8,060 17,770	5,220 11,510	6.61 (21.7)	
-4.5 m -14.8 ft	kg lb			*10,170 *22,420	9,350 20,610				*8,590 *18,940	7,760 17,110	5.12 (16.8)	

- Lifting capacity are based on ISO 10567.
- Lifting capacity of HX-LT3 Series does not exceed 75% of tipping load with the machine on firm, level ground or 87% of full hydraulic capacity.
- The Lift-point is bucket pivot mounting pin on the arm(without bucket mass).
- (\*) indicates load limited by hydraulic capacity.

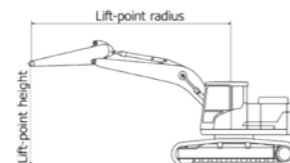

Rating over-front Rating over-side or 360 degree

## HX260 L

5.85 m (19' 2") boom, 3.05 m (10' 0") arm equipped triple grouser shoe. (without bucket)

Lift-point height (m/ft)	Lift-point radius										At max. reach		
	1.5 m (4.9 ft)		3.0 m (9.8 ft)		4.5 m (14.8 ft)		6.0 m (19.7 ft)		7.5 m (24.6 ft)		Capacity		Reach
													m (ft)
7.5 m 24.6 ft	kg lb										*5,640 *12,430	*5,640 *12,430	6.66 (21.8)
6.0 m 19.7 ft	kg lb										*5,760 *12,700	*5,760 *12,700	7.70 (25.3)
4.5 m 14.8 ft	kg lb										*7,520 *16,580	*7,520 *16,580	8.34 (27.4)
3.0 m 9.8 ft	kg lb										*10,060 *22,180	9,890 21,800	8.67 (28.5)
1.5 m 4.9 ft	kg lb										*12,400 *27,340	9,200 20,280	8.74 (28.7)
Ground Line	kg lb										*6,350 *14,000	*6,350 *14,000	8.53 (28.0)
-1.5 m -4.9 ft	kg lb	*7,180 *15,830	*7,180 *15,830	*11,200 *24,690	*11,200 *24,690	*13,990 *30,840	8,730 19,250	9,080 20,020	5,740 12,650	6,510 14,350	4,210 9,280	8.04 (26.4)	
-3.0 m -9.8 ft	kg lb	*12,130 *26,740	*12,130 *26,740	*17,610 *38,820	*17,610 *38,820	*13,350 *29,430	8,810 19,420	9,120 20,110	5,780 12,740			7.21 (23.7)	
-4.5 m -14.8 ft	kg lb										*16,130 *35,560	*16,130 *35,560	5.88 (19.3)

5.85 m (19' 2") boom, 3.60 m (11' 8") arm equipped triple grouser shoe. (without bucket)

Lift-point height (m/ft)	Lift-point radius										At max. reach					
	1.5 m (4.9 ft)		3.0 m (9.8 ft)		4.5 m (14.8 ft)		6.0 m (19.7 ft)		7.5 m (24.6 ft)		9.0m (29.5ft)		Capacity		Reach	
															m (ft)	
9.0 m 29.5 ft	kg lb													*3,960 *8,730	*3,960 *8,730	5.83 (19.1)
7.5 m 24.6 ft	kg lb													*3,480 *7,670	*3,480 *7,670	7.32 (24.0)
6.0 m 19.7 ft	kg lb													*5,160 *11,380	4,880 10,760	8.27 (27.1)
4.5 m 14.8 ft	kg lb													*5,870 *12,940	*5,870 *12,940	8.87 (29.1)
3.0 m 9.8 ft	kg lb													*8,950 *19,730	*8,950 *19,730	9.19 (30.1)
1.5 m 4.9 ft	kg lb													*11,490 *25,330	9,300 20,500	9.25 (30.3)
Ground Line	kg lb													*7,080 *15,610	*7,080 *15,610	9.05 (29.7)
-1.5 m -4.9 ft	kg lb	*6,440 *14,200	*6,440 *14,200	*10,510 *23,170	*10,510 *23,170	*13,840 *30,510	8,620 19,000	8,990 19,820	5,650 12,460	6,420 14,150	4,130 9,110			8.60 (28.2)		
-3.0 m -9.8 ft	kg lb	*10,440 *23,020	*10,440 *23,020	*15,470 *34,110	*15,470 *34,110	*13,580 *29,940	8,630 19,030	8,980 19,800	5,640 12,430	6,450 14,220	4,150 9,150			7.82 (25.7)		
-4.5 m -14.8 ft	kg lb													*15,510 *34,190	*15,510 *34,190	6.62 (21.7)

- Lifting capacity are based on ISO 10567.
- Lifting capacity of HX-LT3 Series does not exceed 75% of tipping load with the machine on firm, level ground or 87% of full hydraulic capacity.
- The Lift-point is bucket pivot mounting pin on the arm(without bucket mass).
- (\*) indicates load limited by hydraulic capacity.

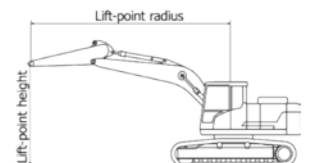

# LIFTING CAPACITY

Rating over-front Rating over-side or 360 degree

## HX260 L HIGH WALKER

5.85 m (19' 2") boom, 2.10 m (6' 9") arm equipped triple grouser shoe. (without bucket)

Lift-point height (m/ft)	Lift-point radius								At max. reach		
	3.0 m (9.8 ft)		4.5 m (14.8 ft)		6.0 m (19.7 ft)		7.5 m (24.6 ft)		Capacity		Reach
											m (ft)
7.5 m 24.6 ft	kg lb								*7,200 *15,870	*7,200 *15,870	5.91 (19.4)
6.0 m 19.7 ft	kg lb			*7,800 *17,200	*7,800 *17,200	*7,110 *15,670	*7,110 *15,670		*7,130 *15,720	6,500 14,330	6.98 (22.9)
4.5 m 14.8 ft	kg lb			*9,890 *21,800	*9,890 *21,800	*7,920 *17,460	*7,920 *17,460	*7,230 *15,940	5,720 12,610	5,590 12,320	7.61 (25.0)
3.0 m 9.8 ft	kg lb					*9,010 *19,860	7,730 17,040	*7,610 *16,780	5,610 12,370	5,190 11,440	7.90 (25.9)
1.5 m 4.9 ft	kg lb					*9,940 *21,910	7,480 16,490	*8,040 *17,730	5,490 12,100	5,110 11,270	7.90 (25.9)
Ground Line	kg lb			*14,140 *31,170	11,220 24,740	*10,380 *22,880	7,360 16,230	8,130 17,920	5,450 12,020	5,350 11,790	7.60 (24.9)
-1.5 m -4.9 ft	kg lb	*13,230 *29,170	*13,230 *29,170	*13,550 *29,870	11,290 24,890	*10,130 *22,330	7,380 16,270		*8,390 *18,500	6,060 13,360	6.97 (22.9)
-3.0 m -9.8 ft	kg lb	*16,040 *35,360	*16,040 *35,360	*11,860 *26,150	11,520 25,400				*8,640 *19,050	7,820 17,240	5.89 (19.3)
-4.5 m -14.8 ft	kg lb										

5.85 m (19' 2") boom, 2.50 m (8' 2") arm equipped triple grouser shoe. (without bucket)

Lift-point height (m/ft)	Lift-point radius								At max. reach			
	3.0 m (9.8 ft)		4.5 m (14.8 ft)		6.0 m (19.7 ft)		7.5 m (24.6 ft)		Capacity		Reach	
											m (ft)	
7.5 m 24.6 ft	kg lb					*6,460 *14,240	*6,460 *14,240			*5,940 *13,100	5,940 13,100	6.33 (20.8)
6.0 m 19.7 ft	kg lb					*6,620 *14,590	*6,620 *14,590			*5,620 *12,390	5,620 12,390	7.34 (24.1)
4.5 m 14.8 ft	kg lb			*9,160 *20,190	*9,160 *20,190	*7,490 *16,510	*7,490 *16,510	*6,810 *15,010	5,760 12,700	5,260 11,600	7.94 (26.0)	
3.0 m 9.8 ft	kg lb			*11,700 *25,790	*11,700 *25,790	*8,650 *19,070	7,780 17,150	*7,320 *16,140	5,620 12,390	4,890 10,780	8.22 (27.0)	
1.5 m 4.9 ft	kg lb			*13,500 *29,760	11,370 25,070	*9,690 *21,360	7,500 16,530	*7,840 *17,280	5,480 12,080	4,820 10,630	8.22 (27.0)	
Ground Line	kg lb			*14,110 *31,110	11,190 24,670	*10,280 *22,660	7,350 16,200	8,090 17,840	5,400 11,900	5,020 11,070	7.93 (26.0)	
-1.5 m -4.9 ft	kg lb	*13,530 *29,830	*13,530 *29,830	*13,790 *30,400	11,210 24,710	*10,240 *22,580	7,330 16,160		*8,060 *17,770	5,600 12,350	7.33 (24.0)	
-3.0 m -9.8 ft	kg lb	*17,300 *38,140	*17,300 *38,140	*12,460 *27,470	11,400 25,130	*9,140 *20,150	7,480 16,490		*8,460 *18,650	7,000 15,430	6.31 (20.7)	
-4.5 m -14.8 ft	kg lb											

- Lifting capacity are based on ISO 10567.
- Lifting capacity of HX-LT3 Series does not exceed 75% of tipping load with the machine on firm, level ground or 87% of full hydraulic capacity.
- The Lift-point is bucket pivot mounting pin on the arm(without bucket mass).
- (\*) indicates load limited by hydraulic capacity.

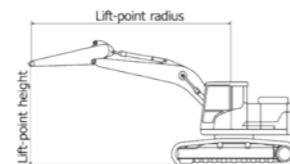

Rating over-front Rating over-side or 360 degree

## HX260 L HIGH WALKER

5.85 m (19' 2") boom, 3.05 m (10' 0") arm equipped triple grouser shoe. (without bucket)

Lift-point height (m/ft)	Lift-point radius										At max. reach			
	1.5 m (4.9 ft)		3.0 m (9.8 ft)		4.5 m (14.8 ft)		6.0 m (19.7 ft)		7.5 m (24.6 ft)		Capacity		Reach	
													m (ft)	
9.0 m 29.5 ft	kg lb											*4,460 *9,830	*4,460 *9,830	5.47 (18.0)
7.5 m 24.6 ft	kg lb							*5,580 *12,300	*5,580 *12,300			*3,930 *8,660	*3,930 *8,660	6.96 (22.8)
6.0 m 19.7 ft	kg lb							*5,910 *13,030	*5,910 *13,030	*5,380 *11,860	*5,380 *11,860	*3,750 *8,270	*3,750 *8,270	7.89 (25.9)
4.5 m 14.8 ft	kg lb			*11,330 *24,980	*11,330 *24,980	*8,090 *17,840	*8,090 *17,840	*6,840 *15,080	*6,840 *15,080	*6,270 *13,820	5,790 12,760	*3,750 *8,270	*3,750 *8,270	8.45 (27.7)
3.0 m 9.8 ft	kg lb					*10,690 *23,570	*10,690 *23,570	*8,070 *17,790	7,830 17,260	*6,880 *15,170	5,620 12,390	*3,890 *8,580	*3,890 *8,580	8.71 (28.6)
1.5 m 4.9 ft	kg lb					*12,820 *28,260	11,430 25,200	*9,240 *20,370	7,510 16,560	*7,510 *16,560	5,450 12,020	*4,200 *9,260	*4,200 *9,260	8.71 (28.6)
Ground Line	kg lb			*7,450 *16,420	*7,450 *16,420	*13,860 *30,560	11,140 24,560	*10,020 *22,090	7,300 16,090	*7,950 *17,530	5,340 11,770	*4,740 *10,450	4,540 10,010	8.44 (27.7)
-1.5 m -4.9 ft	kg lb	*8,350 *18,410	*8,350 *18,410	*12,570 *27,710	*12,570 *27,710	*13,920 *30,690	11,090 24,450	*10,240 *22,580	7,230 15,940	*7,970 *17,570	5,320 11,730	*5,710 *12,590	4,990 11,000	7.88 (25.8)
-3.0 m -9.8 ft	kg lb	*13,480 *29,720	*13,480 *29,720	*18,690 *41,200	*18,690 *41,200	*13,030 *28,730	11,210 24,710	*9,640 *21,250	7,310 16,120			*7,740 *17,060	6,010 13,250	6.94 (22.8)
-4.5 m -14.8 ft	kg lb			*14,980 *33,030	*14,980 *33,030	*10,580 *23,320	*10,580 *23,320					*8,320 *18,340	*8,320 *18,340	5.45 (17.9)

5.85 m (19' 2") boom, 3.60 m (11' 8") arm equipped triple grouser shoe. (without bucket)

Lift-point height (m/ft)	Lift-point radius										At max. reach					
	1.5 m (4.9 ft)		3.0 m (9.8 ft)		4.5 m (14.8 ft)		6.0 m (19.7 ft)		7.5 m (24.6 ft)		9.0m (29.5ft)		Capacity		Reach	
															m (ft)	
9.0 m 29.5 ft	kg lb							*4,480 *9,880	*4,480 *9,880					*3,800 *8,380	*3,800 *8,380	6.26 (20.5)
7.5 m 24.6 ft	kg lb									*3,740 *8,250	*3,740 *8,250			*3,410 *7,520	*3,410 *7,520	7.59 (24.9)
6.0 m 19.7 ft	kg lb							*5,190 *11,440	*5,190 *11,440	*5,290 *11,660	*5,290 *11,660			*3,270 *7,210	*3,270 *7,210	8.45 (27.7)
4.5 m 14.8 ft	kg lb							*6,150 *13,560	*6,150 *13,560	*5,740 *12,650	*5,740 *12,650			*3,270 *7,210	*3,270 *7,210	8.97 (29.4)
3.0 m 9.8 ft	kg lb					*9,610 *21,190	*9,610 *21,190	*7,440 *16,400	*7,440 *16,400	*6,410 *14,130	5,630 12,410	*4,490 *9,900	4,230 9,330	*3,390 *7,470	*3,390 *7,470	9.22 (30.3)
1.5 m 4.9 ft	kg lb					*12,000 *26,460	11,520 25,400	*8,720 *19,220	7,520 16,580	*7,120 *15,700	5,430 11,970	*4,910 *10,820	4,140 9,130	*3,630 *8,000	*3,630 *8,000	9.22 (30.3)
Ground Line	kg lb			*7,780 *17,150	*7,780 *17,150	*13,430 *29,610	11,090 24,450	*9,670 *21,320	7,260 16,010	*7,690 *16,950	5,290 11,660			*4,050 *8,930	*4,050 *8,930	8.97 (29.4)
-1.5 m -4.9 ft	kg lb	*7,370 *16,250	*7,370 *16,250	*11,560 *25,490	*11,560 *25,490	*13,860 *30,560	10,950 24,140	*10,110 *22,290	7,140 15,740	7,910 17,440	5,220 11,510			*4,780 *10,540	4,450 9,810	8.44 (27.7)
-3.0 m -9.8 ft	kg lb	*11,540 *25,440	*11,540 *25,440	*17,020 *37,520	*17,020 *37,520	*13,370 *29,480	11,010 24,270	*9,870 *21,760	7,160 15,790	*7,110 *15,670	5,280 11,640			*6,170 *13,600	5,210 11,490	7.58 (24.9)
-4.5 m -14.8 ft	kg lb			*16,730 *36,880	*16,730 *36,880	*11,650 *25,680	11,280 24,870	*8,340 *18,390	7,370 16,250					*7,820 *17,240	7,000 15,430	6.24 (20.5)

- Lifting capacity are based on ISO 10567.
- Lifting capacity of HX-LT3 Series does not exceed 75% of tipping load with the machine on firm, level ground or 87% of full hydraulic capacity.
- The Lift-point is bucket pivot mounting pin on the arm(without bucket mass).
- (\*) indicates load limited by hydraulic capacity.

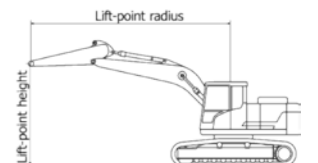

# STANDARD / OPTION

ENGINE	STD	OPT
Hyundai HE6.7 Engine (Manufactured by Cummins)	●	
<b>HYDRAULIC SYSTEM</b>		
INTELLIGENT POWER CONTROL (IPC)		
3-power mode, 2-work mode, user mode	●	
Variable power control	●	
Pump flow control	●	
Attachment mode flow control		●
Engine auto idle	●	
Engine auto shutdown control		●
<b>CAB &amp; INTERIOR</b>		
ISO STANDARD CABIN		
Rise-up type windshield wiper	●	
Radio / USB player	●	
12 volt power outlet (24V DC to 12V DC converter)	●	
All-weather steel cab with 360° visibility	●	
Safety glass windows	●	
Safety glass - Tempered glass	●	
Safety glass - Tempered glass with front laminated glass		●
Sliding fold-in front window	●	
Sliding side window(LH)	●	
Lockable door	●	
Hot & cool box	●	
Storage compartment & Ashtray	●	
Sun visor	●	
Door and cab locks, one key	●	
Cabin lights		●
Cabin front window rain guard		●
Transparent cabin roof-cover	●	
Cabin roof-steel cover		●
<b>AUTOMATIC CLIMATE CONTROL</b>		
Air conditioner & heater	●	
Defroster	●	
Starting Aid (air grid heater) for cold weather	●	
<b>CENTRALIZED MONITORING</b>		
8" LCD display - Normal type	●	
8" LCD display - Premium type		●
Engine speed or Trip meter / Accel	●	
Engine coolant temperature gauge	●	
Max power	●	
Low speed / High speed	●	
Auto idle	●	
Overload warning with alarm		●
Air cleaner clogging	●	
Indicators	●	
ECO gauges	●	
Fuel level gauge	●	
Hyd. oil temperature gauge	●	
Fuel warmer		●
Warnings	●	
Communication error	●	
Low battery	●	
Clock	●	
<b>SEAT</b>		
Mechanical suspension without heater		●
Mechanical suspension with heater	●	
Adjustable air suspension without heater		●
Adjustable air suspension with heater		●
<b>CABIN FOPS (ISO 10262) LEVEL 2</b>		
FOPS (Falling Object Protective Structure) - ISO 10262 Level 2	Front & Top guard	●
	Top guard	●
<b>CABIN ROPS</b>		
ROPS (Roll Over Protective Structures) - ISO 12117-2		●

SAFETY	STD	OPT
Battery master switch	●	
Rearview camera		●
AAVM (Advanced Around View Monitoring)		●
Front working lights	●	
Travel alarm	●	
Rear work lamp		●
Beacon lamp		●
Automatic swing brake	●	
Boom holding system	●	
Arm holding system	●	
Safety lock valve for boom cylinder with overload warning device		●
Safety lock valve for arm cylinder		●
Swing lock system		●
Outside rearview mirror	●	
<b>ATTACHMENT</b>		
<b>BOOMS</b>		
5.85m, 19' 2"	●	
<b>ARMS</b>		
2.1 m, 6' 11"		●
2.5 m, 8' 2"		●
3.05 m, 10' 0"	●	
3.60 m, 11' 10"		●
<b>OTHERS</b>		
Work lamp LED		●
Handsfree mobile phone system with USB	●	
Electric horn	●	
Pilot-operated slidable joystick	●	
Removable clean-out dust net for cooler	●	
Removable reservoir tank	●	
Fuel Pre-Filter (w/o Warmer)		●
Fuel Pre-Filter (with Single Warmer)	●	
Fuel Pre-Filter (with Dual Warmer)		●
Self-diagnostics system	●	
Hi MATE (Remote Management System)		●
Batteries (2 x 12V x 80 AH)	●	
Fuel filler pump (50 L/lpm)		●
Single-acting piping kit (breaker, etc.)		●
Double-acting piping kit (clamshell, etc.)		●
Rotating piping kit		●
Quick coupler piping		●
Quick coupler		●
Accumulator for lowering work equipment	●	
Pattern change valve (2 patterns)		●
Fine Swing Control System		●
General type guardrail	●	
Tool kit		●
Rain cap	●	
Pre cleaner		●
<b>COUNTERWEIGHT</b>		
4.6 ton CWT	●	
5.1 ton CWT		●
<b>UNDERCARRIAGE</b>		
Lower frame under cover (Additional)		●
Lower frame under cover (Normal)	●	
<b>TRACK SHOES</b>		
Triple Grousers Shoes (600 mm, 24")	●	
Triple Grousers Shoes (700 mm, 28")		●
Triple Grousers Shoes (800 mm, 32")		●
Triple Grousers Shoes (900 mm, 36")		●
Triple Grousers Shoes (700 mm, 28")		●
Track rail guard	●	
Full track rail guard		●

\* Standard and optional equipment may vary. Contact your Hyundai dealer for more information. The machine may vary according to International standards.  
 \* The photos may include attachments and optional equipment that are not available in your area.  
 \* Materials and specifications are subject to change without advance notice.  
 \* All imperial measurements rounded off to the nearest pound or inch.

# MEMO

---

**MEMO**

---

**MEMO**